

auto electrical parts

Technical Information Sheet

Part No. 0-668-91

Durite Interior Lamp with touch button switch. SMD 2525 LED's
10-30VDC. 22 white SMD LED's.
PC Lens with ADC12 Housing. IP67. E Marked
EMC R10. 20cm flying leads. Current Draw
0.26A @ 12VDC, 0.15A @ 24VDC.



Technical Drawing (not to scale)

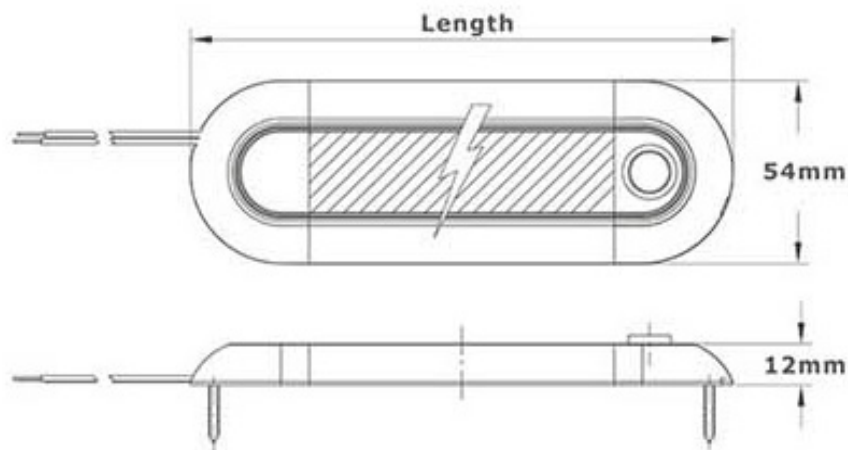

Specification

Type	Linear LED Interior Lamp
Voltage	10-30VDC
LED	22 x 0.2W
Power	4.4W
Illumination	195Lumens
Lux @ 1 Meter	65 Lux
Material	PC Lens, ADC12 Housing
Protection	IP67
Operating Temperature	-25°C to 65°C
Switch	Touch
Dimensions	160*54*12mm
Compliance	CE, EMC R10

The information contained in this document is correct to the best of our knowledge at the time of printing. However, specifications may change at any time without notice.